



Pain

Ronald Melzack¹ and Joel Katz^{2*}

Pain has many valuable functions. It often signals injury or disease, generates a wide range of adaptive behaviors, and promotes healing through rest. Despite these beneficial aspects of pain, there are negative features that challenge our understanding of the puzzle of pain, including persistent phantom limb pain after amputation or total spinal cord transection. Pain is a personal, subjective experience influenced by cultural learning, the meaning of the situation, attention, and other psychological variables. Pain processes do not begin with the stimulation of receptors. Rather, injury or disease produces neural signals that enter an active nervous system that (in the adult organism) is the substrate of past experience, culture, and a host of other environmental and personal factors. These brain processes actively participate in the selection, abstraction, and synthesis of information from the total sensory input. Pain is not simply the end product of a linear sensory transmission system; it is a dynamic process that involves continuous interactions among complex ascending and descending systems. The neuromatrix theory guides us away from the Cartesian concept of pain as a sensation produced by injury, inflammation, or other tissue pathology and toward the concept of pain as a multidimensional experience produced by multiple influences. These influences range from the existing synaptic architecture of the neuromatrix—which is determined by genetic and sensory factors—to influences from within the body and from other areas in the brain. Genetic influences on synaptic architecture may determine—or predispose toward—the development of chronic pain syndromes. © 2012 John Wiley & Sons, Ltd.

How to cite this article:

WIREs Cogn Sci 2013, 4:1–15. doi: 10.1002/wcs.1201

INTRODUCTION

We all know that pain has many valuable functions. It often signals injury or disease and generates a wide range of behaviors to end it and to treat its causes. Chest pain, for example, may be a symptom of heart disease, and may compel us to seek a physician's help. Memories of past pain and suffering also serve as signals for us to avoid potentially dangerous situations. Yet another beneficial effect of pain, notably after serious injury or disease, is to make us rest, thereby promoting the body's healing processes. All of these actions induced by pain—to escape, avoid, or rest—have obvious value for survival.

*Correspondence to: jkatz@yorku.ca

¹Department of Psychology, McGill University, Montreal, Quebec, Canada

²Department of Psychology, York University, Toronto, Ontario, Canada

Despite these beneficial aspects of pain, there are negative features that challenge our understanding of the puzzle of pain. What is the benefit of chronic phantom limb pain to an amputee whose stump has healed completely? The pain, not the physical impairment, prevents them from leading a normal life. Likewise, most backaches, headaches, muscle pains, nerve pains, pelvic pains, and facial pains serve no discernible purpose, are resistant to treatment, and are a catastrophe for the people who are afflicted.

Pain may be the warning signal that saves the lives of some people, but it destroys the lives of countless others. Chronic pains, clearly, are not a warning to prevent physical injury or disease. They *are* the disease—the result of neural mechanisms gone awry.^{1–3} In this section, we review past and current theories of pain, including the Neuromatrix theory which suggests brain mechanisms that may underlie some kinds of chronic pain and points to new forms of treatment.

A BRIEF HISTORY OF PAIN

The theory of pain we inherited in the 20th century was proposed by Descartes three centuries earlier. The impact of Descartes' specificity theory was enormous. It influenced experiments on the anatomy and physiology of pain up to the first half of the 20th century (reviewed in Ref 4). This body of research is marked by a search for specific pain fibers and pathways and a pain center in the brain. The result was a concept of pain as a specific, direct-line sensory projection system. This rigid anatomy of pain in the 1950s led to attempts to treat severe chronic pain by a variety of neurosurgical lesions. Descartes' specificity theory, then, determined the 'facts' as they were known up to the middle of the 20th century, and even determined therapy.

Specificity theory proposed that injury activates specific pain receptors and fibers which, in turn, project pain impulses through a spinal pain pathway to a pain center in the brain. The psychological experience of pain, therefore, was virtually equated with peripheral injury. In the 1950s, there was no room for psychological contributions to pain, such as attention, past experience, anxiety, depression, and the meaning of the situation. Instead, pain experience was held to be proportional to peripheral injury or pathology. Patients who suffered back pain without presenting signs of organic disease were often labeled as psychologically disturbed and sent to psychiatrists. The concept was simple and often failed to help patients who suffered severe chronic pain. To thoughtful clinical observers,^{5,6} specificity theory was clearly wrong.

There were several attempts to find a new theory. The major opponent to specificity theory was labeled as 'pattern theory', but there were several different pattern theories and they were generally vague and inadequate (see Ref 4). However, pattern theories gradually evolved (Figure 1) and set the stage for the gate control theory. Goldscheider⁷ proposed that central summation in the dorsal horns is one of the critical determinants of pain. Livingston⁵ postulated a reverberatory circuit in the dorsal horns to explain summation, referred pain and pain that persisted long after healing was completed. Noordenbos⁸ proposed that large-diameter fibers inhibited small-diameter fibers, and he even suggested that the substantia gelatinosa in the dorsal horns plays a major role in the summation of incoming nerve impulses and other dynamic processes described by Livingston.⁵ However, in none of these theories was there an explicit role for the brain other than as a passive receiver of messages. Nevertheless, the successive theoretical concepts moved the field in the right direction: into the spinal cord and away from the periphery as the

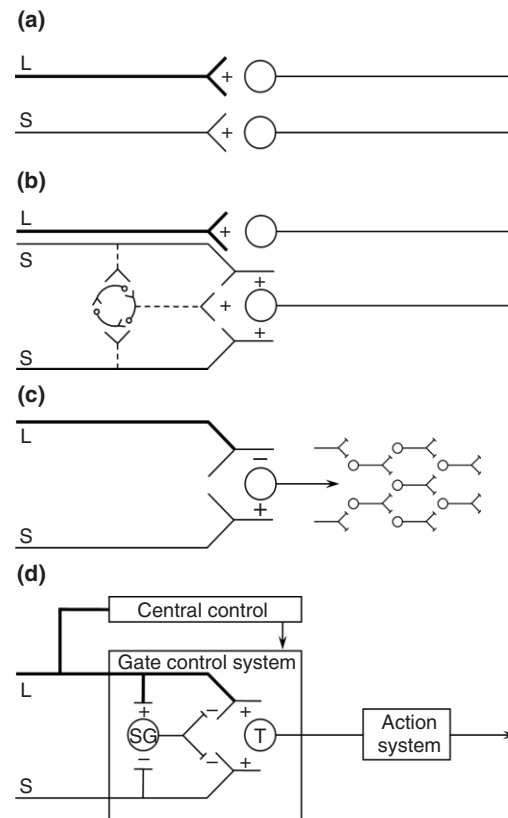

FIGURE 1 | Schematic representation of conceptual models of pain mechanisms. (a) Specificity theory. Large (L) and small (S) fibers are assumed to transmit touch and pain impulses, respectively, in separate, specific, straight-through pathways to touch and pain centers in the brain. (b) Goldscheider's⁷ summation theory, showing convergence of small fibers onto a dorsal horn cell. The central network projecting to the central cell represents Livingston's⁵ conceptual model of reverberatory circuits underlying pathological pain states. Touch is assumed to be carried by large fibers. (c) Sensory interaction theory, in which large (L) fibers inhibit (–) and small (S) fibers excite (+) central transmission neurons. The output projects to spinal cord neurons, which are conceived by Noordenbos⁸ to comprise a multisynaptic afferent system. (D) Gate control theory. The large (L) and small (S) fibers project to the substantia gelatinosa (SG) and first central transmission (T) cells. The central control trigger is represented by a line running from the large fiber system to central control mechanisms, which in turn project back to the gate control system. The T cells project to the entry cells of the action system. +, excitation; –, inhibition. (Reprinted with permission from Ref 9. Copyright 1991 Elsevier Ltd)

exclusive answer to pain. At least the field of pain was making its way up toward the brain.

THE GATE CONTROL THEORY OF PAIN

Theories of pain, like all scientific theories, evolve as result of the accumulation of new facts as well as leaps of the imagination.¹⁰ In 1965, Melzack and Wall¹¹

proposed the gate control theory of pain. The final model, depicted in Figure 1(d), is the first theory of pain to incorporate the central control processes of the brain.

The gate control theory of pain¹¹ proposed that the transmission of nerve impulses from afferent fibers to spinal cord transmission (T) cells is modulated by a gating mechanism in the spinal dorsal horn. This gating mechanism is influenced by the relative amount of activity in large- and small-diameter fibers, so that large fibers tend to inhibit transmission (close the gate) while small-fibers tend to facilitate transmission (open the gate). In addition, the spinal gating mechanism is influenced by nerve impulses that descend from the brain. When the output of the spinal T cells exceeds a critical level, it activates the Action System—those neural areas that underlie the complex, sequential patterns of behavior and experience characteristic of pain.

The theory's emphasis on the modulation of inputs in the spinal dorsal horns and the dynamic role of the brain in pain processes had a clinical as well as a scientific impact. Psychological factors, which were previously dismissed as 'reactions to pain', were now seen to be an integral part of pain processing and new avenues for pain control by psychological therapies were opened. Similarly, cutting nerves and pathways were gradually replaced by a host of methods to modulate the input. Physical therapists and other health-care professionals were brought into the picture, and transcutaneous electrical nerve stimulation became an important modality for the treatment of chronic and acute pain. The current status of pain research and therapy indicates that, despite the addition of a massive amount of detail, the conceptual components of the theory have stood the test of time.¹²

BEYOND THE GATE

We believe the great challenge ahead of us is to understand brain function. Melzack and Casey¹³ made a start by proposing that specialized systems in the brain are involved in the sensory-discriminative, motivational-affective and cognitive-evaluative dimensions of subjective pain experience (Figure 2). These names for the dimensions of subjective experience seemed strange when they were coined, but they are now used so frequently and seem so 'logical' that they have become part of our language. So too, the McGill Pain Questionnaire, which taps into subjective experience—one of the functions of the brain—is the most widely used to instrument to measure pain.^{14–16} The newest version, the Short-Form

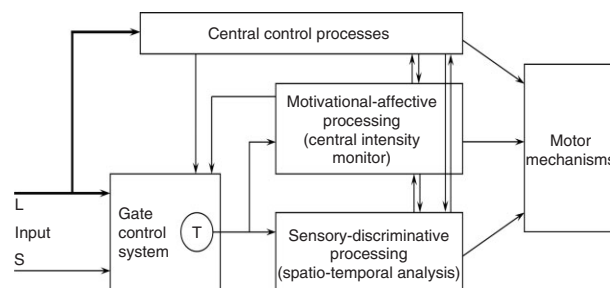

FIGURE 2 | Conceptual model of the sensory, motivational, and central control determinants of pain. The output of the T (transmission) cells of the gate control system projects to the sensory-discriminative system and the motivational-affective system. The central control trigger is represented by a line running from the large fiber system to central control processes; these, in turn, project back to the gate control system, and to the sensory-discriminative and motivational-affective systems. All three systems interact with one another, and project to the motor system. (Reprinted with permission from Ref 13. Copyright 1968 Charles C Thomas Publisher Ltd)

McGill Pain Questionnaire-2,¹⁶ was designed to measure the qualities of both neuropathic and non-neuropathic pain in research and clinical settings.

In 1978, Melzack and Loeser¹⁷ described severe pains in the phantom body of paraplegic patients with verified total sections of the spinal cord, and proposed a central 'pattern generating mechanism' above the level of the section. This concept represented a revolutionary advance: it did not merely extend the gate; it said that pain could be generated by brain mechanisms in paraplegic patients in the absence of a spinal gate because the brain is completely disconnected from the cord. Psychophysical specificity, in such a concept, makes no sense; instead we must explore how patterns of nerve impulses generated in the brain can give rise to somesthetic experience.

Phantom Limbs and the Concept of a Neuromatrix

It is evident that the gate control theory has taken us a long way. Yet, as historians of science have pointed out, good theories are instrumental in producing facts that eventually require a new theory to incorporate them. And this is what has happened. It is possible to make adjustments to the gate theory so that, for example, it includes long-lasting activity of the sort Wall has described (see Ref 4). But there is a set of observations on pain in paraplegic patients that just does not fit the theory. This does not negate the gate theory, of course. Peripheral and spinal processes are obviously an important part of pain and we need to know more about the mechanisms of

peripheral inflammation, spinal modulation, midbrain descending control, and so forth. But the data on painful phantoms below the level of total spinal cord section^{18,19} indicate that we need to go above the spinal cord and into the brain.

Note that we mean more than the spinal projection areas in the thalamus and cortex. These areas are important, of course, but they are only part of the neural processes that underlie perception. The cortex, Gybels and Tasker made amply clear, is not the pain center and neither is the thalamus.²⁰ The areas of the brain involved in pain experience and behavior must include somatosensory projections as well as the limbic system. Furthermore, cognitive processes are known to involve widespread areas of the brain. Despite this increased knowledge, we do not have yet an adequate theory of how the brain works.

Melzack's¹⁹ analysis of phantom limb phenomena, particularly the astonishing reports of a phantom body and severe phantom limb pain in people with a total thoracic spinal cord section,¹⁷ led to four conclusions which pointed to a new conceptual model of the nervous system. First, because the phantom limb feels so real, it is reasonable to conclude that the body we normally feel is subserved by the same neural processes in the brain as the phantom; these brain processes are normally activated and modulated by inputs from the body but they can act in the absence of any inputs. Second, all the qualities of experience we normally feel from the body, including pain, are also felt in the absence of inputs from the body; from this we may conclude that the origins of the patterns of experience lie in neural networks in the brain; stimuli may trigger the patterns but do not produce them. Third, the body is perceived as a unity and is identified as the 'self', distinct from other people and the surrounding world. The experience of a unity of such diverse feelings, including the self as the point of orientation in the surrounding environment, is produced by central neural processes and cannot derive from the peripheral nervous system or spinal cord. Fourth, the brain processes that underlie the body-self are 'built-in' by genetic specification, although this built-in substrate must, of course, be modified by experience, including social learning and cultural influences. These conclusions provide the basis of the conceptual model^{18,19,21} depicted in Figure 3.

Outline of the Theory

The anatomical substrate of the body-self is a large, widespread network of neurons that consists of loops between the thalamus and cortex as well as between the cortex and limbic system.^{18,19,21} The entire network, whose spatial distribution and synaptic links are

initially determined genetically and are later sculpted by sensory inputs, is a *neuromatrix*. The loops diverge to permit parallel processing in different components of the neuromatrix and converge repeatedly to permit interactions between the output products of processing. The repeated *cyclical processing and synthesis* of nerve impulses through the neuromatrix imparts a characteristic pattern: the *neurosignature*. The neurosignature of the neuromatrix is imparted on all nerve impulse patterns that flow through it; the neurosignature is produced by the patterns of synaptic connections in the entire neuromatrix. All inputs from the body undergo cyclical processing and synthesis so that characteristic patterns are impressed on them in the neuromatrix. Portions of the neuromatrix are specialized to process information related to major sensory events (such as injury, temperature change and stimulation of erogenous tissue) and may be labeled as neuromodules which impress sub signatures on the larger neurosignature.

The neurosignature, which is a continuous output from the body-self neuromatrix, is projected to areas in the brain—the *sentient neural hub*—in which the stream of nerve impulses (the neurosignature modulated by ongoing inputs) is converted into a continually changing stream of awareness. Furthermore, the neurosignature patterns may also activate a second neuromatrix to produce movement, the action-neuromatrix. That is, the signature patterns bifurcate so that a pattern proceeds to the sentient neural hub (where the pattern is transformed into the experience of movement) and a similar pattern proceeds through a neuromatrix that eventually activates spinal cord neurons to produce muscle patterns for complex actions.

The Body-Self Neuromatrix

The body is felt as a unity, with different qualities at different times. The brain mechanism that underlies the experience also comprises a unified system that acts as a whole and produces a neurosignature pattern of a whole body.^{18,19,21} The conceptualization of this unified brain mechanism lies at the heart of the theory, and the word 'neuromatrix' best characterizes it. The neuromatrix (not the stimulus, peripheral nerves or 'brain center') is the origin of the neurosignature; the neurosignature originates and takes form in the neuromatrix. Though the neurosignature may be activated or modulated by input, the input is only a 'trigger' and does not produce the neurosignature itself. The neuromatrix 'casts' its distinctive signature on all inputs (nerve impulse patterns) which flow through it. Finally, the array of neurons in a neuromatrix is genetically programmed to perform the

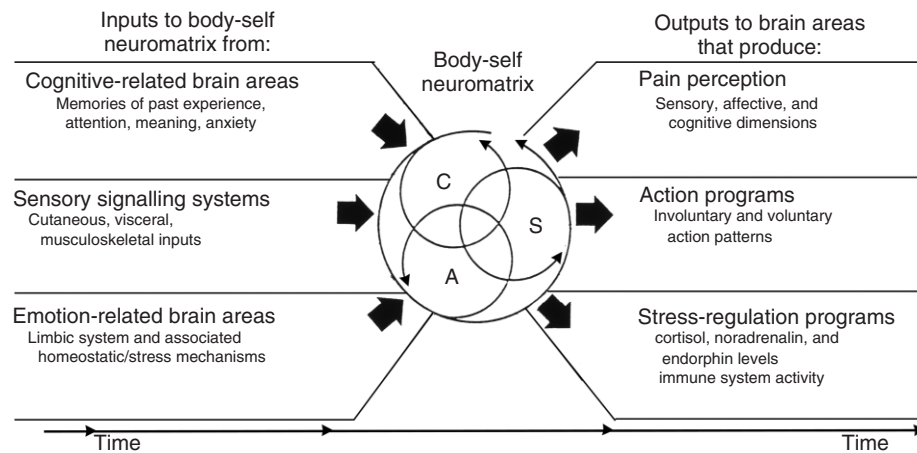

FIGURE 3 | Factors that contribute to the patterns of activity generated by the body-self neuromatrix, which is comprised of sensory, affective, and cognitive neuromodules. The output patterns from the neuromatrix produce the multiple dimensions of pain experience, as well as concurrent homeostatic and behavioral responses. (Reprinted with permission from Ref 21. Copyright 2001 Sage Publications)

specific function of producing the signature pattern. The final, integrated neurosignature pattern for the body-self ultimately produces awareness and action.

The neuromatrix, distributed throughout many areas of the brain, comprises a widespread network of neurons which generates patterns, processes information that flows through it, and ultimately produces the pattern that is felt as a whole body. The stream of neurosignature output with constantly varying patterns riding on the main signature pattern produces the feelings of the whole body with constantly changing qualities.

Conceptual Reasons for a Neuromatrix

It is difficult to comprehend how individual bits of information from skin, joints, or muscles can all come together to produce the experience of a coherent, articulated body. At any instant in time, millions of nerve impulses arrive at the brain from all the body's sensory systems, including the proprioceptive and vestibular systems. How can all this be integrated in a constantly changing unity of experience? Where does it all come together?

Melzack^{18,19,21} conceptualized a genetically built-in neuromatrix for the whole body, producing a characteristic neurosignature for the body which carries with it patterns for the myriad qualities we feel. The neuromatrix produces a continuous message that represents the whole body in which details are differentiated within the whole as inputs come into it. We start from the top, with the experience of a unity of the body, and look for differentiation of detail within the whole. The neuromatrix, then, is a template of the whole, which provides the characteristic neural pattern for the whole body (the

body's neurosignature) as well as subsets of signature patterns (from neuromodules) that relate to events at (or in) different parts of the body.

These views are in sharp contrast to the classical specificity theory in which the qualities of experience are presumed to be inherent in peripheral nerve fibers. Pain is not injury; the *quality of pain experiences* must not be confused with the physical event of breaking skin or bone. Warmth and cold are not 'out there'; temperature changes occur 'out there', but the *qualities of experience* must be generated by structures in the brain. There are no external equivalents to stinging, smarting, tickling, itch; the *qualities* are produced by built-in neuromodules whose neurosignatures innately produce the qualities.

We do not learn to feel qualities of experience: our brains are built to produce them. The inadequacy of the traditional peripheralist view becomes especially evident when we consider paraplegic patients with high-level complete spinal cord transections. In spite of the absence of inputs from the body, virtually every quality of sensation and affect is experienced. It is known that the absence of input produces hyperactivity and abnormal firing patterns in spinal cells above the level of the break.¹⁷ But how, from this jumble of activity, do we get the meaningful experience of movement, the coordination of limbs with other limbs, cramping pain in specific muscle groups, and so on? This must occur in the brain, in which neurosignatures are produced by neuromatrices that are triggered by the output of hyperactive cells.

When all sensory systems are intact, inputs modulate the continuous neuromatrix output to produce the wide variety of experiences we feel. We may feel position, warmth, and several kinds of pain

and pressure all at once. It is a single unitary feeling just as an orchestra produces a single unitary sound at any moment even though the sound comprises violins, cellos, horns, and so forth. Similarly, at a particular moment in time we feel complex qualities from all of the body. In addition, our experience of the body includes visual images, affect, 'knowledge' of the self (versus not-self) as well as the meaning of body parts in terms of social norms and values. It is hard to imagine of all of these bits and pieces coming together to produce a unitary body-self, but we can conceive of a neuromatrix which impresses a characteristic signature on all the inputs that converge on it and thereby produces the never-ending stream of feeling from the body.

The experience of the body-self involves multiple dimensions—sensory, affective, evaluative, postural and many others. The sensory dimensions are subserved, in part at least, by portions of the neuromatrix that lie in the sensory projection areas of the brain; the affective dimensions are subserved by areas in the brainstem and limbic system. Each major psychological dimension (or quality) of experience is subserved by a particular portion of the neuromatrix which contributes a distinct portion of the total neurosignature.^{18,19,21} To use a musical analogy once again, it is like the strings, tympani, woodwinds and brasses of a symphony orchestra which each comprise a part of the whole; each makes its unique contribution yet is an integral part of a single symphony which varies continually from beginning to end.

The neuromatrix resembles Hebb's 'cell assembly' and Bindra's 'gnostic organization' by being a widespread network of cells that subserves a particular psychological function. However, the neural networks proposed by Hebb²² and Bindra²³ developed by gradual sensory learning, whereas Melzack, instead, conceived the structure of the neuromatrix to be predominantly determined by genetic factors, although its eventual synaptic architecture is influenced by sensory inputs. This emphasis on the genetic contribution to the brain does not diminish the importance of sensory inputs. The neuromatrix is a psychologically meaningful unit, developed by both heredity and learning, that represents an entire unified entity.

Action Patterns: The Action-Neuromatrix

The output of the body neuromatrix is directed at two systems: (1) the neuromatrix that produces awareness of the output, and (2) a neuromatrix involved in overt action patterns. Just as there is a steady stream of awareness, there is also a steady output of behavior (including movements during sleep). It is important to recognize that behavior occurs only after the input

has been at least partially synthesized and recognized. For example, when we respond to the experience of pain or itch, it is evident that the experience has been synthesized by the body-self neuromatrix (or relevant neuromodules) sufficiently for the neuromatrix to have imparted the neurosignature patterns that underlie the quality of experience, affect and meaning. Most behavior occurs only after inputs have been analyzed and synthesized sufficiently to produce meaningful experience. When we reach for an apple, the visual input has clearly been synthesized by a neuromatrix so that it has 3-dimensional shape, color and meaning as an edible, desirable object, all of which are produced by the brain and are not in the object 'out there'. When we respond to pain (by withdrawal or even by telephoning for an ambulance), we respond to an experience that has sensory qualities, affect and meaning as a dangerous (or potentially dangerous) event to the body.

After inputs from the body undergo transformation in the body-neuromatrix, the appropriate action patterns are activated concurrently (or nearly so) with the neuromatrix for experience. Thus, in the action-neuromatrix, cyclical processing and synthesis produces activation of several possible patterns, and their successive elimination, until one particular pattern emerges as the most appropriate for the circumstances at the moment. In this way, input and output are synthesized simultaneously, in parallel, not in series. This permits a smooth, continuous stream of action patterns.

The command, which originates in the brain, to perform an action such as running activates the neuromodule which then produces firing in sequences of neurons that send precise messages through ventral horn neuron pools to appropriate sets of muscles. At the same time, the output patterns from the body-neuromatrix that engage the neuromodules for particular actions are also projected to the sentient neural hub and produce experience. In this way, the brain commands may produce the experience of movement of phantom limbs even though there are no limbs to move and no proprioceptive feedback. Indeed, reports by paraplegics of terrible fatigue due to persistent bicycling movements²⁴ and the painful fatigue in a tightly clenched phantom fist in arm-amputees^{6,25} indicate that feelings of effort and fatigue are produced by the signature of a neuromodule rather than particular input patterns from muscles and joints.

The phenomenon of phantom limbs has allowed us to examine some fundamental assumptions in psychology. One assumption is that sensations are produced only by stimuli and that perceptions in the absence of stimuli are psychologically abnormal. Yet

phantom limbs, as well as phantom seeing,²⁶ indicate this notion is wrong. The brain does more than detect and analyze inputs; it generates perceptual experience even when no external inputs occur.

Another entrenched assumption is that perception of one's body results from sensory inputs that leave a memory in the brain; the total of these signals becomes the body image. But the existence of phantoms in people born without a limb or who have lost a limb at an early age suggests that the neural networks for perceiving the body and its parts are built into the brain.^{18,19,27,28} The absence of inputs does not stop the networks from generating messages about missing body parts; they continue to produce such messages throughout life. In short, phantom limbs are a mystery only if we assume the body sends sensory messages to a passively receiving brain. Phantoms become comprehensible once we recognize that the brain generates the experience of the body. Sensory inputs merely modulate that experience; they do not directly cause it.

Pain and Neuroplasticity

There was no place in the specificity concept of the nervous system for 'plasticity,' in which neuronal and synaptic functions are capable of being molded or shaped so that they influence subsequent perceptual experiences. Plasticity related to pain represents persistent functional changes, or 'somatic memories,'^{29–31} produced in the nervous system by injuries or other pathological events. The recognition that such changes can occur is essential to understanding chronic pain syndromes, such as low back pain and phantom limb pain that often destroy the lives of the people who suffer them.

Denervation Hypersensitivity and Neuronal Hyperactivity

Sensory disturbances associated with nerve injury have been closely linked to alterations in CNS function. Markus et al.³² have demonstrated that the development of hypersensitivity in a rat's hindpaw following sciatic nerve section occurs concurrently with the expansion of the saphenous nerve's somatotopic projection in the spinal cord. Nerve injury may also lead to the development of increased neuronal activity at various levels of the somatosensory system (see review by Coderre et al.³³). In addition to spontaneous activity generated from the neuroma, peripheral neurectomy also leads to increased spontaneous activity in the dorsal root ganglion, and spinal cord. Furthermore, after dorsal

rhizotomy, there are increases in spontaneous neural activity in the dorsal horn, the spinal trigeminal nucleus, and the thalamus.

Clinical neurosurgery studies reveal a similar relationship between denervation and CNS hyperactivity. Neurons in the somatosensory thalamus of patients with neuropathic pain display high spontaneous firing rates, abnormal bursting activity, and evoked responses to stimulation of body areas that normally do not activate these neurons.^{34,35} The site of abnormality in thalamic function appears to be somatotopically related to the painful region. In patients with complete spinal cord transection and dysesthesias referred below the level of the break, neuronal hyperactivity was observed in thalamic regions that had lost their normal sensory input, but not in regions with apparently normal afferent input.³⁴ Furthermore, in patients with neuropathic pain, electrical stimulation of subthalamic, thalamic and capsular regions may evoke pain³⁶ and in some instances even reproduce the patient's pain.^{37–39} Direct electrical stimulation of spontaneously hyperactive cells evokes pain in some but not all pain patients, raising the possibility that in certain patients the observed changes in neuronal activity may contribute to the perception of pain.³⁴ Studies of patients undergoing electrical brain stimulation during brain surgery reveal that pain is rarely elicited by test stimuli unless the patient suffers from a chronic pain problem. However, brain stimulation can elicit pain responses in patients with chronic pain that does not involve extensive nerve injury or deafferentation. Lenz et al.³⁸ described the case of a woman with unstable angina who, during electrical stimulation of the thalamus, reported 'heart pain like what I took nitroglycerin for' except that 'it starts and stops suddenly' (p. 121). The possibility that the patient's angina was due to myocardial strain, and not the activation of a somatosensory pain memory, was ruled out by demonstrating that EKG, blood pressure, and cardiac enzymes remained unchanged over the course of stimulation.

It is possible that receptive field expansions and spontaneous activity generated in the CNS following peripheral nerve injury are, in part, mediated by alterations in normal inhibitory processes in the dorsal horn. Within four days of a peripheral nerve section there is a reduction in the dorsal root potential, and therefore, in the presynaptic inhibition it represents.⁴⁰ Nerve section also induces a reduction in the inhibitory effect of A-fiber stimulation on activity in dorsal horn neurons.⁴¹ Furthermore, nerve injury affects descending inhibitory controls from brainstem nuclei. In the intact nervous system, stimulation of the locus coeruleus⁴² or the nucleus raphe magnus⁴³ produces

an inhibition of dorsal horn neurons. Following dorsal rhizotomy, however, stimulation of these areas produces excitation, rather than inhibition, in half the cells studied.⁴⁴

Recent advances in our understanding of the mechanisms that underlie pathological pain have important implications for the treatment of both acute and chronic pain. Since it has been established that intense noxious stimulation produces a sensitization of CNS neurons, it is possible to direct treatments not only at the site of peripheral tissue damage, but also at the site of central changes (see review by Coderre et al.⁴⁵). Furthermore, it may be possible in some instances to prevent the development of central sensitization which contributes to pathological pain states. The evidence that acute post-operative pain intensity and/or the amount of pain medication patients require after surgery are reduced by perioperative administration of variety of agents *via* the epidural^{46–48} or systemic route^{49–51} suggests that the surgically-induced afferent injury barrage arriving within the CNS, and the central sensitization it induces, can be prevented or at least obtunded significantly.^{52,53} The reduction in acute pain intensity associated with preoperative epidural anesthesia may even translate into reduced pain⁵⁴ and pain disability⁵⁵ weeks after patients have left the hospital and returned home.

The fact that amputees are more likely to develop phantom limb pain if there is pain in the limb prior to amputation³⁰ raises the possibility that the development of longer term neuropathic pain also can be prevented by reducing the potential for central sensitization at the time of amputation.^{52,53} Whether chronic post-operative problems such as painful scars, post-thoracotomy chest-wall pain, and phantom limb and stump pain can be reduced by blocking peri-operative nociceptive inputs awaits additional well-controlled clinical trials.^{56,57} Furthermore, research is required to determine whether multi-modal approaches may also prevent or relieve other forms of severe chronic pain such as post-herpetic neuralgia⁵⁸ and complex regional pain syndrome. It is hoped that a combination of new pharmacological developments, careful clinical trials, and an increased understanding of the mechanisms underlying noxious stimulus-induced neuroplasticity, will lead to improved clinical treatment and prevention of pathological pain.

Pain and Psychopathology

Pains that do not conform to present-day anatomical and neurophysiological knowledge are often attributed to psychological dysfunction. This view of the role of psychological generation in pain persists

to this day notwithstanding evidence to the contrary. Psychopathology has been proposed to underlie phantom limb pain,²⁵ dyspareunia,⁵⁹ orofacial pain,⁶⁰ and a host of others including pelvic pain, abdominal pain, chest pain and headache.⁶¹ However, the complexity of the pain transmission circuitry described in the previous sections means that many pains that defy our current understanding will ultimately be explained without having to resort to a psychopathological etiology. Pain that is 'nonanatomical' in distribution, spread of pain to non-injured territory, pain that is said to be out of proportion to the degree of injury, and pain in the absence of injury have all, at one time or another, been used as evidence to support the idea that psychological disturbance underlies the pain. Yet each of these features of supposed psychopathology can now be explained by neurophysiological mechanisms that involve an interplay between peripheral and central neural activity.^{4,60}

Recent data linking the immune and central nervous systems have provided an explanation for another heretofore medically unexplained pain problem. Mirror image pain or *allochira* has puzzled clinicians and basic scientists ever since it was first documented in the late 1800s.⁶² Injury to one side of the body is experienced as pain at the site of injury as well as at the contralateral, mirror image point.^{6,63} Animal studies show induction of a sciatic inflammatory neuritis by peri-sciatic microinjection of immune system activators results in both an ipsilateral hyperalgesia and hyperalgesia at the mirror image point on the opposite side in the territory of the contralateral healthy sciatic nerve.⁶⁴ Moreover, both the ipsilateral and contralateral hyperalgesia are prevented or reversed by intrathecal injection of a variety of proinflammatory cytokine antagonists.⁶⁵

Mirror image pain is likely not a unitary phenomenon and other non-immune mechanisms may also be involved.⁶⁶ For example, human⁶⁷ and animal evidence⁶⁸ point to a potential combination of central and peripheral contributions to mirror-image pain since nerve injury to one side of the body has been shown to result in a 50% reduction in the innervation of the territory of the same nerve on the opposite side of the body in uninjured skin.⁶⁸ Interestingly, while documented contralateral neurite loss can occur in the absence of contralateral pain or hyperalgesia, pain intensity at the site of the injury correlates significantly with the extent of contralateral neurite loss.⁶⁷ This raises the intriguing possibility that the intensity of pain at the site of an injury may be facilitated by contralateral neurite loss induced by the ipsilateral injury⁶⁸—a situation that most clinicians would never have imagined possible.

Taken together, these novel mechanisms that explain some of the most puzzling pain symptoms must keep us mindful that emotional distress and psychological disturbance in our patients are not at the root of the pain. In fact, more often than not, prolonged pain is the cause of distress, anxiety, and depression. This is not to say that psychological and emotion distress do not contribute to pain nor that pain cannot be caused by thoughts and feelings even in psychologically healthy people. But strange and unusual pains should not be taken as a proxy for psychopathology. Attributing pain to a psychological disturbance is damaging to the patient and provider alike; it poisons the patient-provider relationship by introducing an element of mutual distrust and implicit (and at times, explicit) blame. It is devastating to the patient who feels at fault, disbelieved and alone.

Pain and Stress

We are so accustomed to considering pain as a purely sensory phenomenon that we have ignored the obvious fact that injury does not merely produce pain; it also disrupts the brain's homeostatic regulation systems, thereby producing 'stress' and initiating complex programs to reinstate homeostasis. By recognizing the role of the stress system in pain processes, we discover that the scope of the puzzle of pain is vastly expanded and new pieces of the puzzle provide valuable clues in our quest to understand chronic pain.⁶⁹

Hans Selye, who founded the field of stress research, dealt with stress in the biological sense of physical injury, infection, and pathology, but also recognized the importance of psychological stressors. In recent years, the latter sense of the word has come to dominate the field. However, it is important for the purpose of understanding pain to keep in mind that stress involves a biological system that is activated by physical injury, infection, or any threat to biological homeostasis, as well as by psychological threat and insult of the body-self.

The disruption of homeostasis by injury activates programs of neural, hormonal, and behavioral activity aimed at a return to homeostasis. The particular programs that are activated are selected from a genetically determined repertoire of programs and are influenced by the extent and severity of the injury. When injury occurs, sensory information rapidly alerts the brain and begins the complex sequence of events to re-establish homeostasis. Cytokines are released within seconds after injury. These substances, such as gamma-interferon, interleukins 1 and 6, and tumor necrosis factor, enter the bloodstream within 1–4 min and travel to the brain. The cytokines,

therefore, are able to activate fibers that send messages to the brain and, concurrently, to breach the blood–brain barrier at specific sites and have an immediate effect on hypothalamic cells. The cytokines together with evaluative information from the brain rapidly begin a sequence of activities aimed at the release and utilization of glucose for necessary actions, such as removal of debris, the repair of tissues, and (sometimes) fever to destroy bacteria and other foreign substances. Following severe injury, the noradrenergic system is activated: epinephrine is released into the blood stream and the powerful locus coeruleus/norepinephrine system in the brainstem projects information upward throughout the brain and downward through the descending efferent sympathetic nervous system. Thus, the whole sympathetic system is activated to produce readiness of the heart, blood vessels, and other viscera for complex programs to reinstate homeostasis.^{70,71}

At the same time, the perception of injury activates the hypothalamic–pituitary–adrenal (HPA) system and the release of cortisol from the adrenal cortex, which inevitably plays a powerful role in determining chronic pain. Cortisol also acts on the immune system and the endogenous opioid system. Although these opioids are released within minutes, their initial function may be simply to inhibit or modulate the release of cortisol. Experiments with animals suggest that their analgesic effects may not appear until as long as 30 min after injury.

Cortisol is an essential hormone for survival because it is responsible for producing and maintaining high levels of glucose for rapid response after injury or major threat. However, cortisol is potentially a highly destructive substance because, to ensure a high level of glucose, it breaks down the protein in muscle and inhibits the ongoing replacement of calcium in bone. Sustained cortisol release, therefore, can produce myopathy, weakness, fatigue, and decalcification of bone. It can also accelerate neural degeneration of the hippocampus during aging. Furthermore, it suppresses the immune system.

A major clue to the relationships among injury, stress, and pain is that many autoimmune diseases, such as rheumatoid arthritis and scleroderma, are also pain syndromes. Furthermore, more women than men suffer from autoimmune diseases as well as chronic pain syndromes.⁷² Among the 5% of adults who have an autoimmune disease, two out of three are women. Of particular importance is the change in sex ratios concurrently with changes in sex hormone output as a function of age. Estrogen increases the release of peripheral cytokines, such as gamma-interferon,

which in turn produce increased cortisol. This may explain why more females than males suffer from most kinds of chronic pain as well as painful autoimmune diseases such as multiple sclerosis and lupus.⁷²

Some forms of chronic pain may occur as a result of the cumulative destructive effect of cortisol on muscle, bone, and neural tissue. Furthermore, loss of fibers in the hippocampus due to aging reduces a natural brake on cortisol release which is normally exerted by the hippocampus. As a result, cortisol is released in larger amounts, producing a greater loss of hippocampal fibers and a cascading deleterious effect. This is found in aging primates⁷¹ and presumably also occurs in humans. It could explain the increase of chronic pain problems among older people.

The cortisol output by itself may not be sufficient to cause any of these problems, but rather provides the conditions so that other contributing factors may, all together, produce them. Sex-related hormones, genetic predispositions, psychological stresses derived from social competition, and the hassles of everyday life may act together to influence cortisol release, its amount and pattern, and the effects of the target organs.

These speculations are supported by strong evidence. Chrousos and Gold⁷⁰ have documented the effects of dysregulation of the cortisol system: effects on muscle and bone, to which they attribute fibromyalgia, rheumatoid arthritis, and chronic fatigue syndrome. They propose that they are caused by hypocortisolism, which could be due to depletion of cortisol as a result of prolonged stress. Indeed, Sapolsky⁷¹ attributes myopathy, bone decalcification, fatigue, and accelerated neural degeneration during aging to prolonged exposure to stress.

Clearly, consideration of the relationship between stress-system effects and chronic pain leads directly to examination of the effects of suppression of the immune system and the development of autoimmune effects. The fact that several autoimmune diseases are also classified as chronic pain syndromes—such as Crohn's disease, multiple sclerosis, rheumatoid arthritis, scleroderma, and lupus—suggests that the study of these syndromes in relation to stress effects and chronic pain could be fruitful. Immune suppression, which involves prolonging the presence of dead tissue, invading bacteria, and viruses, could produce a greater output of cytokines, with a consequent increase in cortisol and its destructive effects. Furthermore, prolonged immune suppression may diminish gradually and give way to a rebound, excessive immune response. The immune system's attack on its own body's tissues may produce autoimmune diseases that are also chronic

pain syndromes. Thorough investigation may provide valuable clues for understanding at least some of the terrible chronic pain syndromes that now perplex us and are beyond our control.

In some instances, pain itself may serve as a traumatic stressor. A recent prospective study in large sample of surgical patients suggests that the construct *sensitivity to pain traumatization* (SPT) may be a broad-based vulnerability factor for chronic postsurgical pain.⁷³ SPT was derived from a hierarchical factor analysis of items from several pain related anxiety measures and describes the propensity to develop anxiety-related somatic, cognitive, emotional and behavioral responses to pain that resemble features of a traumatic stress reaction. The results showed that the total SPT score before surgery distinguished between patients with and without chronic postsurgical pain at the one-year follow up. That is, preoperative SPT scores were significantly higher in patients who went on to report persistent pain compared with those who were pain-free at the one year follow-up. SPT may serve as a predisposing factor that triggers specific expressions of pain, such as pain catastrophizing, pain anxiety, and pain avoidance, each of which may have different and unique impacts on the quality of the pain experience as well as on the maintenance of chronic pain. Consistent with the role of stress outlined above, once pain is established, it becomes a stressor in itself and may be activated even in the absence of peripheral input not unlike the situation described above for phantom limb pain.

The Multiple Determinants of Pain

The neuromatrix theory of pain proposes that the neurosignature for pain experience is determined by the synaptic architecture of the neuromatrix, which is produced by genetic and sensory influences. The neurosignature pattern is also modulated by sensory inputs and by cognitive events, such as psychological stress. It may also occur because stressors, physical as well as psychological, act on stress-regulation systems, which may produce lesions of muscle, bone, and nerve tissue, thereby contributing to the neurosignature patterns that give rise to chronic pain. In short, the neuromatrix, as a result of homeostasis-regulation patterns that have failed, may produce neural 'distress' patterns that contribute to the total neuromatrix pattern, and may also produce destruction of tissues that give rise to chronic pains. Each contribution to the neuromatrix output pattern may not by itself produce pain, but both outputs together may do so. The stress-regulation system, with its complex, delicately

balanced interactions, is an integral part of the multiple contributions that give rise to chronic pain. The neuromatrix theory guides us away from the Cartesian concept of pain as a sensation produced by injury, inflammation, or other tissue pathology and toward the concept of pain as a multidimensional experience produced by multiple influences. These influences range from the existing synaptic architecture of the neuromatrix—which is determined by genetic and sensory factors—to influences from within the body and from other areas in the brain. Genetic influences on synaptic architecture may determine—or predispose toward—the development of chronic pain syndromes. Figure 3 summarizes the factors that contribute to the output pattern from the neuromatrix that produces the sensory, affective, and cognitive dimensions of pain experience and behavior.²¹

Implications of the Neuromatrix Concept

Phantom Limb Pain

The neuromatrix theory of brain function, proposed largely on the basis of phantom limb phenomena, provides an explanation for phantom limb pain. Amputees suffer burning, cramping, and other qualities of pain. A prospective study found that 72% of amputees had phantom limb pain one week after amputation, and that 60% had pain 6 months later.⁷⁴ Fifty-five percent of amputees continue to suffer phantom limb pain a median of 50 years after amputation.⁷⁵ Only about 10–12% of amputees obtain pain relief.⁷⁴ The pain is remarkably intractable; although many forms of treatment have been tried, none has proved to be particularly efficacious.

The active body-neuromatrix, in the absence of modulating inputs from the limbs or body, produces a neurosignature pattern, including the high-frequency, bursting pattern that typically follows deafferentation, which is transduced in the sentient neural hub into a hot or burning quality. The cramping pain, however, may be due to messages from the action-neuromodule to move muscles in order to produce movement. In the absence of the limbs, the messages to move the muscles become more frequent and ‘stronger’ in the attempt to move the limb. The end result of the *output* message may be felt as cramping muscle pain. Shooting pains may have a similar origin, in which action-neuromodules attempt to move the body and send out abnormal patterns that are felt as shooting pain. The origins of these pains, then, lie in the brain.

Low-Back Pain

Low back pain is one of the most common types of pain, yet it is poorly understood. It illustrates

the complexity of interactions among different contributing factors and the need for multiple approaches to treat it.⁷⁶ Protruding discs, arthritis of vertebral joints, tumors, and fractures are known to cause low back pain. However, about 60–70% of patients who suffer severe low back pain show no evidence of disc disease, arthritis, or any other symptoms that can be considered the cause of the pain. Even when there are clear-cut physical and neurological signs of disc herniation (in which the disc pushes out of its space and presses against nerve roots), surgery produces complete relief of back pain and related sciatic pain in only about 60% of cases. The rate of success in different reports ranges from 50 to 95%, depending in part on the spatial distribution of the pain. Furthermore, patients with physical signs such as disc herniation in the lower spine are rarely helped by surgical procedures such as fusion of several vertebrae to provide structural support to the back.⁷⁶ A variety of forms of physical therapy are more likely to help low back pain. The most effective is a regimen of exercises that develops the back muscles. Transcutaneous electrical nerve stimulation, ice massage, and acupuncture may also help some patients. Injections of anesthetics into trigger points may be effective as well. Still, despite all of these therapies, many patients continue to suffer severe, unrelenting pain.⁷⁷

A high proportion of cases of chronic back pain may be due to more subtle causes. The perpetual stresses and strains on the vertebral column (at discs and adjacent structures called facet joints) produce an increase in small blood vessels and fibrous tissue in the area.⁷⁸ As a result, there is a release of substances that are known to produce inflammation and pain into local tissues and the blood stream; this whole stress cascade may be triggered repeatedly. The effect of stress-produced substances—such as cortisol and norepinephrine—at sites of minor lesions and inflammation could, if it occurs often and is prolonged, activate a neuromatrix program that anticipates increasingly severe damage and attempts to counteract it. The program to reduce strain and inflammation could include generating the neurosignature for pain—part of a neural program which presumably evolved to induce rest, the repair of injured tissues, and the restoration of homeostasis.

As a result of the persistence of low back pain despite all the available therapies, it is not surprising that psychological interventions, such as relaxation therapy, Cognitive-Behavior Therapy, and Acceptance and Commitment Therapy have become an important approach to the problem. But no one therapy is more effective than the others. In fact, clinics often employ

several procedures at the same time to get the best results.⁷⁹

Fibromyalgia

Fibromyalgia affects 2% of the population, afflicts more females than males (7:1), and reflects the complexity of most chronic pain syndromes.⁸⁰ The major features of fibromyalgia are multiple tender areas ('trigger points') of the skin and muscles, 'aching all over,' increased skin sensitivity to almost every kind of stimulation, major sleep disturbances, and several indices of abnormal functioning of the whole stress-regulation system.

An understanding of fibromyalgia has eluded us because we have failed to recognize the role of stress mechanisms in addition to the obvious sensory manifestations which have dominated research and hypotheses about the nature of fibromyalgia. Melzack's interpretation of the available evidence is that the body-self neuromatrix's response to stressful events fails to turn off when the stressor diminishes, so that the neuromatrix maintains a continuous state of alertness to threat. It is possible that this readiness for action produces fatigue in muscles, comparable to the fatigue felt by paraplegics in their phantom legs when they spontaneously make cycling movements.²⁴ It is also possible that the prolonged tension maintained in particular sets of muscles produces the characteristic pattern of tender spots.

The abnormal neural program of prolonged, centrally maintained alertness may produce a generalized state of perceptual vigilance or 'open sensory gates' to receive information for rapid response to threat. The persistent low-level stress (i.e., the failure of the stress response to cease) would produce anomalous alpha waves during deep sleep, greater feelings of fatigue, higher generalized sensitivity to all sensory inputs, and a low-level, sustained output of the stress-regulation system, reflected in a depletion of circulating cortisol. The results of a recent study⁸¹ of Hatha yoga for women with fibromyalgia support

these suggestions and provide some hope for those afflicted with this demoralizing disease. At the end of an eight-week Hatha yoga program, continuous pain and pain catastrophizing decreased while chronic pain acceptance, levels of mindfulness, and cortisol levels increased (i.e., normalized).

Goldenberg et al.⁸² described striking similarities between fibromyalgia and chronic fatigue syndrome, and note that the frequent reports by patients in both groups that the onset of fibromyalgia or chronic fatigue syndrome was preceded by a flu-like or viral illness suggests an immune system abnormality. However, a large proportion of patients (about 45%) do not report a flu-like illness but instead report a preceding accident, surgical operation, or no apparent cause. This suggests that an abnormal, partially genetically determined mechanism fails to turn off the stress response to viral, psychological, or other types of threat to the body-self.

CONCLUSION

We have traveled a long way from the psychophysical concept that seeks a simple one-to-one relationship between injury and pain. We now have a theoretical framework in which a genetically determined template for the body-self is modulated by the powerful stress system and the cognitive functions of the brain, in addition to the traditional sensory inputs. The neuromatrix theory of pain—which places genetic contributions and the neural-hormonal mechanisms of stress on a level of equal importance with the neural mechanisms of sensory transmission—has important implications for research and therapy. An immediate recommendation is that interdisciplinary pain clinics should expand to include specialists in endocrinology and immunology. Such a collaboration may lead to insights and new research strategies that may reveal the underlying mechanisms of chronic pain and give rise to new therapies to relieve the tragedy of unrelenting suffering associated with needless pain.

REFERENCES

1. Niv D, Devor M. Chronic pain as a disease in its own right. *Pain Pract* 2004, 4:179–181.
2. Siddall PJ, Cousins MJ. Persistent pain as a disease entity: implications for clinical management. *Anest Anal* 2004, 99:510–520.
3. Woolf CJ. Pain: moving from symptom control toward mechanism-specific pharmacologic management. *Ann Intern Med* 2004, 140:441–451.
4. Melzack R, Wall PD. *The Challenge of Pain*. New York: Basic Books; 1996.
5. Livingston WK. *Pain Mechanisms*. New York: Macmillan; 1943.
6. Livingston WK. *Pain and Suffering*. Seattle: IASP Press; 1998.
7. Goldscheider A. *Über den schmerz in physiologischer und klinischer hinsicht*. Berlin: Hirschwald; 1894.

8. Noordenbos W. *Pain*. Amsterdam: Elsevier; 1959.
9. Melzack R. The gate control theory 25 years later: New perspectives on phantom limb pain. In: Bond MR, Charlton JE, Woolf CJ, eds. *Pain Research and Therapy: Proceedings of the VIth World Congress on Pain*. Amsterdam: Elsevier; 1991, 9–21.
10. Kuhn TS. *The Structure of Scientific Revolutions*. Chicago: University of Chicago Press; 1970.
11. Melzack R, Wall PD. Pain mechanisms: a new theory. *Science* 1965, 150:971–979.
12. Dickenson AH. Gate control theory of pain stands the test of time. *Brit J Anaest* 2002, 88:755–757.
13. Melzack R, Casey KL. Sensory, motivational, and central control determinants of pain. In: Kenshalo D, ed. *The Skin Senses*. Springfield, IL: Charles C Thomas; 1968, 423–443.
14. Melzack R. The McGill pain questionnaire: major properties and scoring methods. *Pain* 1975, 1:277–299.
15. Melzack R. The short-form McGill pain questionnaire. *Pain* 1987, 30:191–197.
16. Dworkin RH, Turk DC, Revicki DA, Harding G, Coyne KS, Peirce-Sandner S, Bhagwat D, Everton D, Burke LB, Cowan P, et al. Development and initial validation of an expanded and revised version of the short-form mcgill pain questionnaire (SF-MPQ-2). *Pain* 2009, 144:35–42.
17. Melzack R, Loeser JD. Phantom body pain in paraplegics: evidence for a central “pattern generating mechanism” for pain. *Pain* 1978, 4:195–210.
18. Melzack R. Phantom limbs and the concept of neuromatrix. *Trend Neurosci* 1990, 13:88–92.
19. Melzack R. Phantom limbs, the self, and the brain (The D.O. Hebb memorial lecture). *Canad Psychol* 1989, 30:1–16.
20. Gybels JM, Tasker RR. Central neurosurgery. In: Wall PD, Melzack R, eds. *Textbook of Pain*. Edinburgh: Churchill Livingstone; 1999, 1307–1339.
21. Melzack R. Pain and the neuromatrix in the brain. *J Dental Ed* 2001, 65:1378–1382.
22. Hebb DO. *The Organization of Behavior*. New York: John Wiley & Sons; 1949.
23. Bindra D. *A Theory of Intelligent Behavior*. New York: John Wiley & Sons; 1976.
24. Conomy JP. Disorders of body image after spinal cord injury. *Neurology* 1973, 23:842–850.
25. Katz J. Individual differences in the consciousness of phantom limbs. In: Kunzendorf RG, Wallace B, eds. *Individual Differences in Conscious Experience: First-Person Constraints on Theories of Consciousness, Self-Consciousness, and Subconsciousness*. Amsterdam: John Benjamins Publishing Co; 2000, 45–97.
26. Schultz G, Melzack R. The Charles Bonnet syndrome: “Phantom visual images”. *Perception* 1991, 20:809–825.
27. Melzack R. Phantom limb pain and the brain. In: Bromm B, Desmedt JE, eds. *Pain and the Brain*. New York: Raven Press; 1995, 73–82.
28. Melzack R, Israel R, Lacroix R, Schultz G. Phantom limbs in people with congenital limb deficiency or amputation in early childhood. *Brain* 1997, 120:1603–1620.
29. Salomons T, Osterman JE, Gagliese L, Katz J. Pain flashbacks in posttraumatic stress disorder. *Clin J Pain* 2004, 20:83–87.
30. Katz J, Melzack R. Pain “memories” in phantom limbs: review and clinical observations. *Pain* 1990, 43:319–336.
31. Katz J, Vaccarino AL, Coderre TJ, Melzack R. Injury prior to neurectomy alters the pattern of autotomy in rats. Behavioral evidence of central neural plasticity. *Anesthesiology* 1991, 75:876–883.
32. Markus H, Pomeranz B, Krushelnyky D. Spread of saphenous somatotopic projection map in spinal cord and hypersensitivity of the foot after chronic sciatic denervation in adult rat. *Brain Res* 1984, 296:27–39.
33. Coderre TJ, Katz J, Vaccarino AL, Melzack R. Contribution of central neuroplasticity to pathological pain: review of clinical and experimental evidence. *Pain* 1993, 52:259–285.
34. Lenz FA, Tasker RR, Dostrovsky JO, Kwan HC, Gorecki J, Hirayama T, Murphy JT. Abnormal single-unit activity recorded in the somatosensory thalamus of a quadriplegic patient with central pain. *Pain* 1987, 31:225–236.
35. Lenz FA, Kwan HC, Dostrovsky JO, Tasker RR. Characteristics of the bursting pattern of action potential that occurs in the thalamus of patients with central pain. *Brain Res* 1989, 496:357–360.
36. Tasker RR. Stereotactic surgery. In: Wall PD, Melzack R, eds. *Textbook of Pain*. Edinburgh: Churchill Livingstone; 1989, 840–855.
37. Nathan PW. Pain and nociception in the clinical context. *Phil Trans Royal Soc Lond* 1985, 308:219–226.
38. Lenz FA, Gracely RH, Hope EJ, Baker FH, Rowland LH, Dougherty PM, Richardson RT. The sensation of angina can be evoked by stimulation of the human thalamus. *Pain* 1994, 59:119–125.
39. Davis KD, Tasker RR, Kiss ZH, Hutchison WD, Dostrovsky JO. Visceral pain evoked by thalamic microstimulation in humans. *Neuroreport* 1995, 6:369–374.
40. Wall PD, Devor M. The effect of peripheral nerve injury on dorsal root potentials and on transmission of afferent signals into the spinal cord. *Brain Res* 1981, 209:95–111.
41. Woolf CJ, Wall PD. Chronic peripheral nerve section diminishes the primary afferent A-fibre mediated inhibition of rat dorsal horn neurones. *Brain Res* 1982, 242:77–85.

42. Segal M, Sandberg D. Analgesia produced by electrical stimulation of catecholamine nuclei in the rat brain. *Brain Res* 1977, 123:369–372.
43. Oliveras JL, Guilbaud G, Besson JM. A map of serotonergic structures involved in stimulation producing analgesia in unrestrained freely moving cats. *Brain Res* 1979, 164:317–322.
44. Hodge CJ, Jr, Apkarian AV, Owen MP, Hanson BS. Changes in the effects of stimulation of locus coeruleus and nucleus raphe magnus following dorsal rhizotomy. *Brain Res* 1983, 288:325–329.
45. Coderre TJ, Katz J. Peripheral and central hyperexcitability: Differential signs and symptoms in persistent pain. *Behav Brain Sci* 1997, 20:404–419.
46. Katz J, Cohen L, Schmid R, Chan VWS, Wowk A. Postoperative morphine use and hyperalgesia are reduced by preoperative but not intraoperative epidural analgesia: implications for preemptive analgesia and the prevention of central sensitization. *Anesthesiology* 2003, 98:1449–1460.
47. Katz J, Clairoux M, Kavanagh BP, Roger S, Nierenberg H, Redahan C, Sandler AN. Pre-emptive lumbar epidural anaesthesia reduces postoperative pain and patient-controlled morphine consumption after lower abdominal surgery. *Pain* 1994, 59:395–403.
48. Katz J, Kavanagh BP, Sandler AN, Nierenberg H, Boylan JF, Friedlander M, Shaw BF. Preemptive analgesia: clinical evidence of neuroplasticity contributing to postoperative pain. *Anesthesiology* 1992, 77:439–446.
49. Katz J, Clairoux M, Redahan C, Kavanagh BP, Carroll S, Nierenberg H, Jackson M, Beattie J, Taddio A, Sandler AN. High dose alfentanil pre-empts pain after abdominal hysterectomy. *Pain* 1996, 68:109–118.
50. Katz J, Schmid R, Snijselaar DG, Coderre TJ, McCartney CJ, Wowk A. Pre-emptive analgesia using intravenous fentanyl plus low-dose ketamine for radical prostatectomy under general anesthesia does not produce short-term or long-term reductions in pain or analgesic use. *Pain* 2004, 110:707–718.
51. Snijselaar DG, Cornelisse HB, Schmid RL, Katz J. A randomised, controlled study of peri-operative low dose s(+)-ketamine in combination with postoperative patient-controlled s(+)-ketamine and morphine after radical prostatectomy. *Anaesthesia* 2004, 59:222–228.
52. Katz J, Clarke H, Seltzer Z. Review article: preventive analgesia: quo vadimus? *Anest Anal* 2011, 113:1242–1253.
53. Katz J, Seltzer Z. Transition from acute to chronic post-surgical pain: risk factors and protective factors. *Expert Rev Neurotherapeut* 2009, 9:723–744.
54. Gottschalk A, Smith DS, Jobs DR, Kennedy SK, Lally SE, Noble VE, Grugan KF, Seifert HA, Cheung A, Malkowicz SB, et al. Preemptive epidural analgesia and recovery from radical prostatectomy: a randomized controlled trial. *JAMA* 1998, 279:1076–1082.
55. Katz J, Cohen L. Preventive analgesia is associated with reduced pain disability three weeks but not six months after abdominal gynecological surgery by laparotomy. *Anesthesiology* 2004, 101:169–174.
56. Katz J. Prevention of phantom limb pain by regional anaesthesia. *Lancet* 1997, 349:519–520.
57. Clarke H, Bonin RP, Orser BA, Englesakis M, Wijey-sundera DN, Katz J. The prevention of chronic postsurgical pain using gabapentin and pregabalin: a combined systematic review and meta-analysis. *Anest Anal* 2012, 115:428–442.
58. Manabe H, Dan K, Hirata K, Hori K, Shono S, Tateshi S, Ishino H, Higa K. Optimum pain relief with continuous epidural infusion of local anesthetics shortens the duration of zoster-associated pain. *Clin J Pain* 2004, 20:302–308.
59. Meana M, Binik YM. Painful coitus: a review of female dyspareunia. *J Nerv Ment Dis* 1994, 182:264–272.
60. Gagliese L, Katz J. Medically unexplained pain is not caused by psychopathology. *Pain Res Manage* 2000, 5:251–257.
61. Stoudemire A, Sandhu J. Psychogenic/idiopathic pain syndromes. *Gen Hosp Psychiat* 1987, 9:79–86.
62. Basbaum AI. A new way to lose your nerve. *Sci Aging Knowledge Environ* 2004, 2004:pe15.
63. Maleki J, LeBel AA, Bennett GJ, Schwartzman RJ. Patterns of spread in complex regional pain syndrome, type I (reflex sympathetic dystrophy). *Pain* 2000, 88:259–266.
64. Chacur M, Milligan ED, Gazda LS, Armstrong C, Wang H, Tracey KJ, Maier SF, Watkins LR. A new model of sciatic inflammatory neuritis (SIN): induction of unilateral and bilateral mechanical allodynia following acute unilateral peri-sciatic immune activation in rats. *Pain* 2001, 94:231–244.
65. Milligan ED, Twining C, Chacur M, Biedenkapp J, O'Connor K, Poole S, Tracey K, Martin D, Maier SF, Watkins LR. Spinal glia and proinflammatory cytokines mediate mirror-image neuropathic pain in rats. *J Neurosci* 2003, 23:1026–1040.
66. Koltzenburg M, Wall PD, McMahon SB. Does the right side know what the left is doing? *Trends Neurosci* 1999, 22:122–127.
67. Oaklander AL, Romans K, Horasek S, Stocks A, Hauer P, Meyer RA. Unilateral postherpetic neuralgia is associated with bilateral sensory neuron damage. *Ann Neurol* 1998, 44:789–795.
68. Oaklander AL, Brown JM. Unilateral nerve injury produces bilateral loss of distal innervation. *Ann Neurol* 2004, 55:639–644.
69. Melzack R. Pain and stress: a new perspective. In: Gatchel RJ, Turk DC, eds. *Psychological Factors in Pain*. New York: Guilford Press; 1999, 89–106.
70. Chrousos GP, Gold PW. The concepts of stress and stress system disorders. Overview of physical and behavioral homeostasis. *JAMA* 1992, 267:1244–1252.

71. Sapolsky RM. *Why Zebras Don't Get Ulcers*. New York: W.H.: Freeman 1994.
72. Berkley KJ, Holdcroft A. Sex and gender differences in pain. In: Wall PD, Melzack R, eds. *Textbook of Pain*. Edinburgh: Churchill Livingstone; 1999, 951–965.
73. Kleiman V, Clarke H, Katz J. Sensitivity to pain traumatization: a higher-order factor underlying pain-related anxiety, pain catastrophizing and anxiety sensitivity among patients scheduled for major surgery. *Pain Res Manage* 2011, 16:169–177.
74. Nikolajsen L, Jensen TS. Postamputation pain. In: Melzack R, Wall PD, eds. *Handbook of Pain Management*. Edinburgh: Churchill Livingstone; 2003, 247–257.
75. Wartan SW, Hamann W, Wedley JR, McColl I. Phantom pain and sensation among British veteran amputees. *Brit J Anaest* 1997, 78:652–659.
76. Long MD. Chronic back pain. In: Melzack R, Wall PD, eds. *Handbook of Pain Management*. Edinburgh: Churchill Livingstone; 2003, 67–76.
77. Lehmann JF, de Lateur BJ. Ultrasound, shortwave, microwave, laser, superficial heat and cold in the treatment of pain. In: Melzack R, Wall PD, eds. *Handbook of Pain Management*. Edinburgh: Churchill Livingstone; 2003, 473–483.
78. Jayson MIV. Rheumatoid arthritis. In: Melzack R, Wall PD, eds. *Handbook of Pain Management*. Edinburgh: Churchill Livingstone; 2003, 39–48.
79. Turk DC, Okifuji A. A cognitive-behavioral approach to pain. In: Melzack R, Wall PD, eds. *Handbook of Pain Management*. Edinburgh: Churchill Livingstone; 2003, 533–541.
80. Bennett R. Fibromyalgia. In: Melzack R, Wall PD, eds. *Handbook of Pain Management*. Edinburgh: Churchill Livingstone; 2003, 95–108.
81. Curtis K, Osadchuk A, Katz J. An eight-week yoga intervention is associated with improvements in pain, psychological functioning and mindfulness, and changes in cortisol levels in women with fibromyalgia. *J Pain Res* 4:189–201.
82. Goldenberg DL, Simms RW, Geiger A, Komaroff AL. High frequency of fibromyalgia in patients with chronic fatigue seen in a primary care practice. *Arthrit Rheumat* 1990, 33:381–387.